



TECHNOLOGY THAT PAYS OFF

# Precision distributors

Precise and reliable distribution  
for all spreading systems



# Precision distributors – the core of all spreading systems

On grassland, during crop growth, or during soil cultivation



**Dribble bar systems**  
Vogelsang SwingMax, SwingUp, and DoubleSwing dribble bar system from 6 to 36 meters.



Vogelsang Compax or SwingDrive dribble bar system for self-propelled vehicles from 6 to 24 meters.

## Making spreading a reliable process

### Liquid manure translates into liquid gold

Liquid manure and digestate from biogas plants are materials of high value. They are a natural source of nutrients and can be used to fertilise crops and plants. Using manure for fertilisation purposes reduces the cost of purchasing man made fertilisers. A prerequisite for employing manure for fertilisation purposes is the ability to precisely distribute the material to the

soil. This is why the heart of any manure spreading system is a Vogelsang precision distribution system: It guarantees reliable flow of the homogeneous liquid gold.

### Highest precision

The main requirement for using liquid manure is even spreading. Vogelsang precision distributors provide amazing precision during distribution. Uniformity with a distribution coefficient of under

5 percent can be achieved, making spreading a reliable process.

### Compatible and universal

In fact, Vogelsang precision distributors are the high-tech core of almost every spreading system. Vogelsang distributors can be used with any equipment: dribble hoses, trailing shoe, injectors and cultivators. They turn ordinary spreading equipment into precision equipment.

### Disc injector

with central DosiMat LVX precision distributor for working the liquid manure directly into the grassland.

### Cultivator

with central ExaCut for applying manure directly as a complete unit.

### Disk harrow

with attached ExaCut precision distributor and DN 60 hose outlets for large spreading capacities. Customized installation with the ExaCut parts kit.

### Completely configured or retrofitted

Vogelsang precision distributors can be customized to your spreader or soil cultivating device using our preconfigured parts kits. They are also available as a complete system from nearly all well-known manufacturers of liquid-manure equipment. And, of course, they are available directly from Vogelsang in a Vogelsang dribble bar system.

### Vogelsang precision distributors are available in two series:

#### DosiMat LVX

Precise distribution with a service advantage: even spreading combined with easy and safe maintenance, thanks to the new rotor quick-change system and safety monitoring.

#### ExaCut

Precision in a small package enables maximum working widths. The integrated heavy material separator offers protection from foreign objects.

We have everything covered – typical Vogelsang.

### StripTill with liquid manure

Injector with DosiMat LVX for cultivating soil in strips.

### Trailing shoe spreading system

with ExaCut as the central distributor for grassland fertilization with minimal soiling of feed.



# DosiMat LVX

The central distribution system with the highest precision and many possible configurations

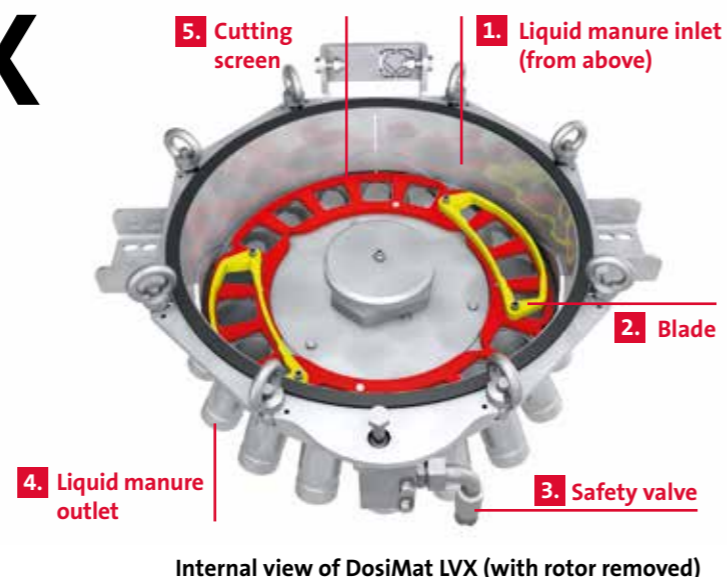

Internal view of DosiMat LVX (with rotor removed)



Perfection in maceration and distribution

DosiMat LVX: versatile, practical, economical

## The DosiMat LVX principle

Liquid manure flows into the distributor from above and is evenly distributed to the outlets by the rotor. Fibrous matter and foreign objects are reliably cut by the rotor blades.

## Unmatched precision

Precise spreading is essential if liquid manure is to be used as a valuable commodity. With a lateral distribution accuracy of up to 5 percent, the DosiMat LVX sets the standard.

## High availability

The rotating blades in the DosiMat LVX cut fibrous matter reliably and safely. They keep the flow of liquid manure constant and minimize clogging. The new blade geometry in the DosiMat LVX and the use of extremely wear-resistant steel increase service life by up to 50 percent.

## Easy inspection

The DosiMat LVX is equipped with a dual seal system. The distributor allows for quick inspection of leakages, giving you peace of mind in knowing that your system is functioning properly.

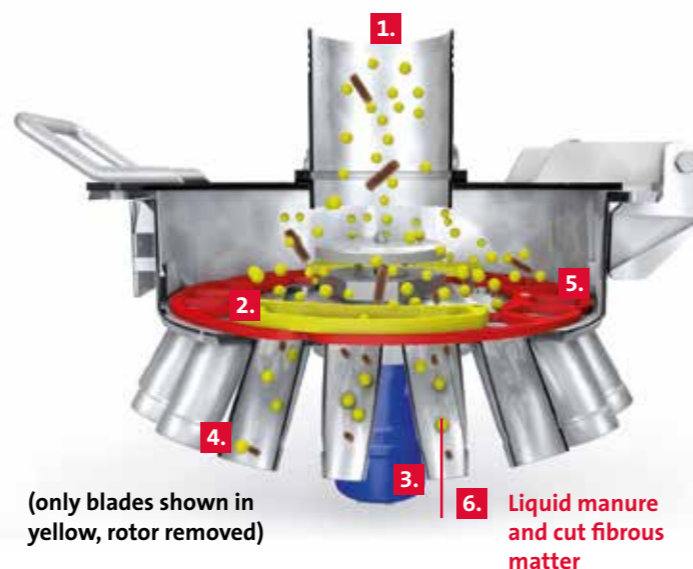

(only blades shown in yellow, rotor removed)

## Quick maintenance

The blades can be changed in just a few steps: unscrew the central rotor screw and remove the spring pins. Replacement blades are readily available from Vogelsang spare parts service. You can find more information at [www.vogelsang.info](http://www.vogelsang.info).

## DosiMat LVX varieties

With over 90 possible configurations, there is a DosiMat LVX for every application. The following variants are available, depending on the pot size.

- 5 to 60 hose outlets
- Star rotor and beam rotor in 3 different widths
- Hose diameter from DN 40 to DN 60
- Various housing sizes

Our agricultural consultants will gladly help you choose the right DosiMat LVX.



The universal version: DosiMat LVX with beam rotor

For large spreading capacities: DosiMat LVX with star rotor



With an optimized blade geometry and heavy-duty materials, we have greatly improved the durability of the cutting system. This also increases the availability and cost-effectiveness of the system.



A safety valve switches the rotor off if the DosiMat LVX is opened during operation.



Fluid losses in the liquid manure or hydraulic system can be detected quickly and easily using the leakage check feature.

# Comfort Flow Control CFC® hose close-off

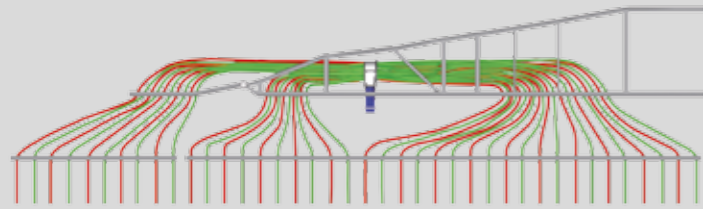

Comfort Flow Control (CFC) – the universal solution for partial width switching, tramline switching, and closing off selected hose groups on the spreading system. For this purpose, CFC is installed in the hose outlets of the spreader device immediately after the distributor. Each individual hose can then be activated and deactivated electropneumatically from the cab at the touch of a button. This is as easy, flexible, and precise as it gets.

CFC can be combined with Vogelsang precision distributors on all spreading systems.

## Advantages and features:

- Simple, reliable principle of operation
- Reliable hose close-off for partial width sections, tramlines, close-off of individual groups
- Hose close-off customized to the field and spreading system
- Quick operation by pressing a button; fully automatic via control from the cab
- Economical spreading even with complex field shapes
- Easy to retrofit on existing dribble bar systems

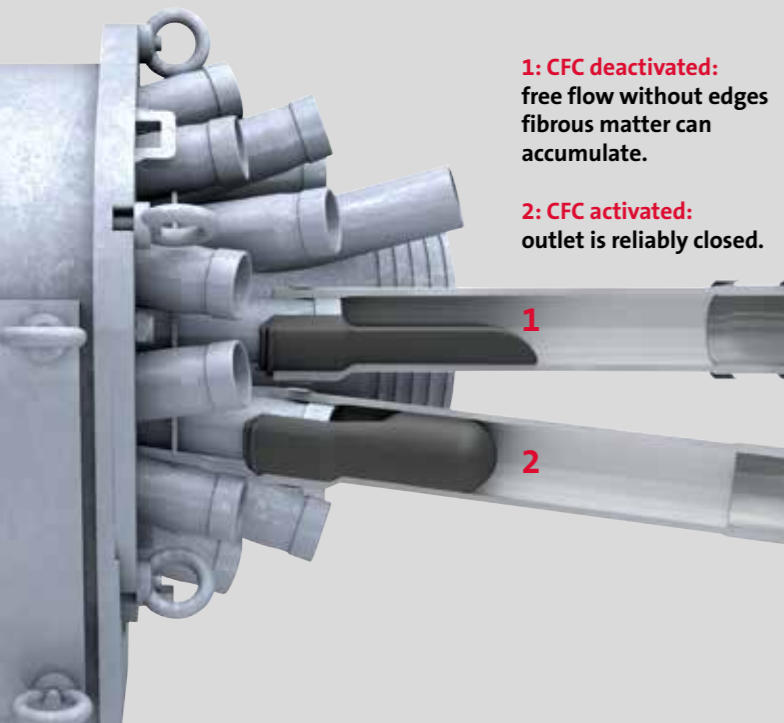

**1: CFC deactivated:**  
free flow without edges  
fibrous matter can  
accumulate.

**2: CFC activated:**  
outlet is reliably closed.

1

2

Precision distributors | Comfort Flow Control | ExaCut

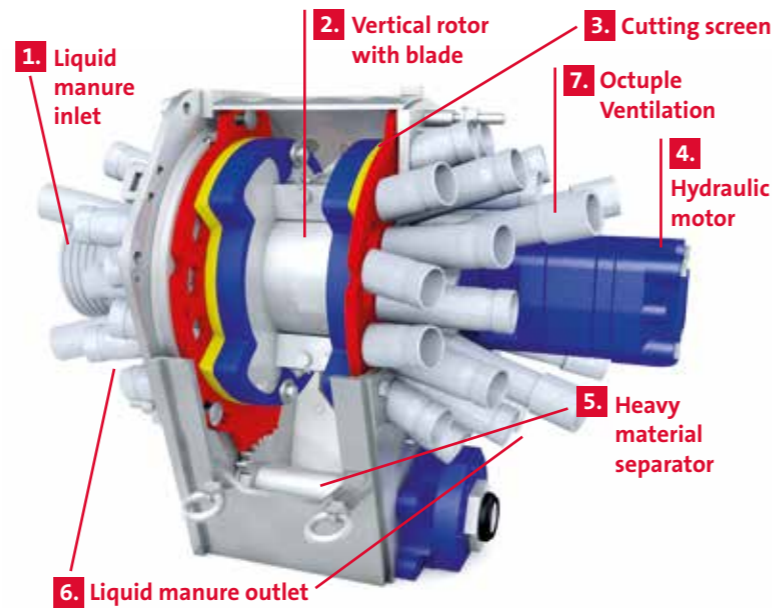

Maximum reliability from a compact design

# ExaCut

## Maximum reliability in a small package

When it comes to space requirements, the ExaCut is unbeatable. Thanks to its high performance capability, the world's smallest precision distributor is well suited for use as a central distributor or a decentralized distributor in a dribble bar or trailing shoe side arm. It cuts and distributes in one step.

As a central distributor, it makes highly compact designs possible. And as a distributor pair in the side arms, it enables large working widths. With ExaCut, working widths of up to 36 meters and systems with up to 96 outputs are now possible.

In addition, all ExaCuts are equipped with a heavy material separator, so stones and metal parts can be easily removed. This saves valuable time during spreading, when every minute counts.

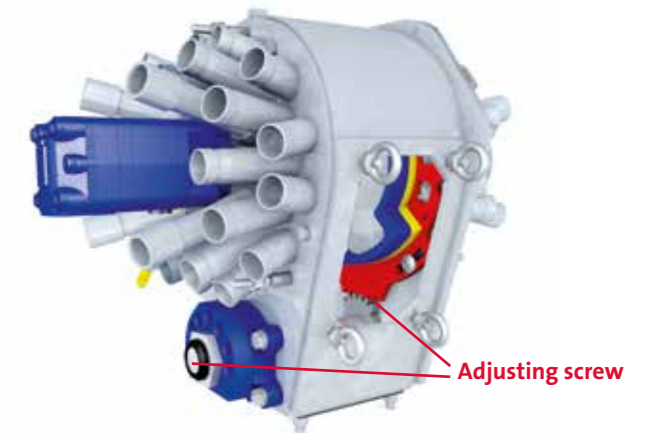
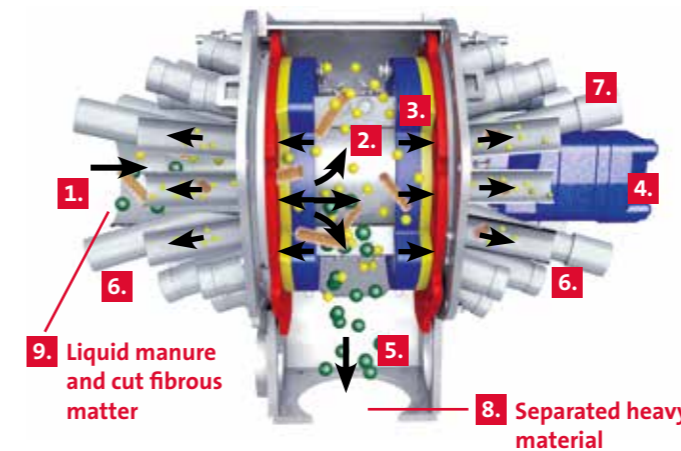

## ExaCut varieties

ExaCut is available in numerous configurations: 12 models are available, from 20 to 60 outlets. The hose diameters correspond to DN 40 or DN 50 depending on the model; DN 60 hoses are also available for 20-outlet models. The cutting rings and rotors can be configured according to the application.

## Inlet adapter

Many variants are available for the liquid manure inlet on the ExaCut. This allows the ExaCut to be customized to the spreading machine.

## ExaCut Vario

The professional solution for contractors that work with varying liquid manure. The type of liquid manure and viscosity affect the distribution accuracy. Different cutting screens are usually necessary for this reason.

To avoid unnecessary cutting screen changes, the ExaCut Vario offers a variable cutting screen geometry. Using the adjusting screw, the cutting system of the ExaCut Vario is easily adapted to liquid manure types having different consistencies. This saves time and allows different types of liquid manure to be spread by a single system.

## Our company

Innovation and progress have been hallmarks of Vogelsang for over 80 years and have made us a leading global plant engineering company. Time and time again we have achieved significant milestones of progress. Today, we develop, manufacture and distribute some of the most innovative and reliable machines and systems for agriculture, municipalities and industry.

With our overseas subsidiaries and service centers, we are world-renowned for advanced engineering and customer-friendly solutions.

## Our product range

We offer solutions for the following areas:

- Industrial sector
- Waste water treatment
- Biogas
- Railway waste water disposal
- Agriculture

We offer a broad range of products:

- Rotary lobe pumps
- Maceration technology
- Distributors
- Spreading technology
- Supply and disposal systems
- Complete solutions

We also offer customized solutions for your specialized applications.

## How to reach us

Vogelsang is present worldwide. Visit us online for more information about our company and wide range of services: **vogelsang.info**

We are here to assist you and look forward to speaking with you.

## Hugo Vogelsang Maschinenbau GmbH

Holthöge 10–14 | 49632 Essen/Oldb., Germany  
Phone: +49 5434 83-0 | Fax: +49 5434 83-10  
info@vogelsang-gmbh.com

## Vogelsang Mechanical Engineering (Shanghai) Co., Ltd

Room 101, No. 173, Jiangchang No. 3 Road  
CN-Shanghai 200436  
Phone: +86 21 61 39 85-01 | Fax: +86 21 61 39 85-02  
sales@vogelsang.com.cn

USA [vogelsangusa.com](http://vogelsangusa.com) | Great Britain [vogelsang.co.uk](http://vogelsang.co.uk)

France [vogelsang.fr](http://vogelsang.fr) | Italy [vogelsang-srl.it](http://vogelsang-srl.it)

Poland [vogelsang.pl](http://vogelsang.pl) | Romania [vogelsang.ro](http://vogelsang.ro)

Czech Republic [vogelsang-czech.cz](http://vogelsang-czech.cz) | Spain [vogelsang.es](http://vogelsang.es)

Australia [vogelsang.com.au](http://vogelsang.com.au) | China [vogelsang.com.cn](http://vogelsang.com.cn)

Denmark [vogelsang-as.dk](http://vogelsang-as.dk) | Sweden [vogelsang.se](http://vogelsang.se)

Ireland [vogelsang.ie](http://vogelsang.ie) | Finland [vogelsang.fi](http://vogelsang.fi)

Mexico [vogelsang.mx](http://vogelsang.mx) | Brazil [vogelsang.com.br](http://vogelsang.com.br)

Malaysia [vogelsang.com.my](http://vogelsang.com.my) | India [vogelsangindia.com](http://vogelsangindia.com)

South Korea [vogelsang.co.kr](http://vogelsang.co.kr) | Russia [vogelsang.ru](http://vogelsang.ru)

Germany – Eastern Branch **Vogelsang Lutherstadt**

**Eisleben** [vogelsang-gmbh.com](http://vogelsang-gmbh.com) | **Vogelsang International**  
[vogelsang-international.com](http://vogelsang-international.com)

Product availability, appearance, technical specifications and details are subject to continuous development. All information presented here is therefore subject to change.